

Surface Texture Measuring Instrument >>>

Quick Response!

Linear Motor Drive Achieves Low-vibration Texture Measurement

SURFCOM 1500DX **1500SD**



SURFCOM 1500DX



SURFCOM 1500SD

● **World's First Linear Motor in a Roughness Instrument (patent pending)**

The world's highest level of measuring speed and lowest vibration enable consistent high-magnification measurements to be performed.

The non-contact drive and simple structure (no feed screw or gear box) of the linear motor ensures stable vibration-free operation over an extended period.

● **High Speed Measurements Dramatically Boost Productivity**

Extremely high speeds have been achieved: Max. 3 mm/s for roughness measurement, Max. 20 mm/s for waviness measurement and movement speed of 60 mm/s (compared to other ACCRETECH model).

● **Newly Developed High-Performance Compact Detector**

A newly developed detector with a compact design that can perform a wide range of high-magnification measurements has been incorporated.

This has provided a measuring range of 1000 μm with an outer diameter of 14mm, and measuring magnification of 500,000 times.

● **Space Saving**

A new design creates a fresh image, and the footprint has been reduced by approximately 25% (compared to previous model).

This helps reduce expenses when installing the unit in a constant-temperature room.

● **Leading in Expandability**

You can easily upgrade from 2D to 3D texture measurement or support both texture (2D/3D) measurement and contour measurement on a single machine just by adding on units.

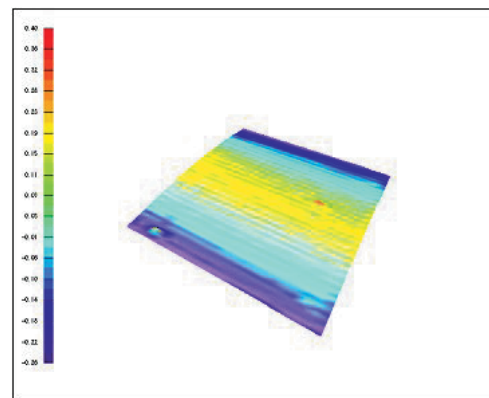

Glass flatness measurement

Measuring range	20mm × 20mm
	1000 lines (Y direction)
Conventional machine	165 minutes
S1500DX-3DF	22 minutes

AI Function Simplifies Measurements (patented)

- The unit automatically selects the measuring conditions without setting them in advance (roughness measurement). In addition, a lesson mode is available to teach the user the operation procedures. This is a reflection of ACCRETECH's commitment to create measuring instruments that anyone can use.

Automation Enhances Measurement Efficiency

- The teaching function can be used to automate a series of operations, from measurement at multiple locations to generation of an inspection report by pasting the data.
- Moving speed of 60mm/s has been realized, which enables drastic increase of measuring efficiency in sequent measurement of whole surfaces.

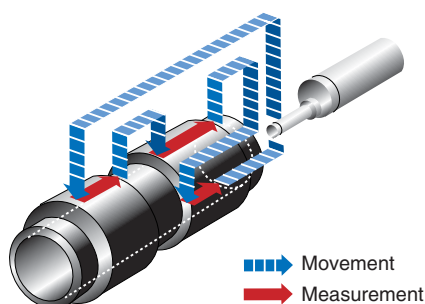

TIMS Flexible Measuring System

- The TIMS next-generation integrated measuring system is a new breakthrough from ACCRETECH. It links different programs with a single icon, enhancing the ease of analysis.

Complies with World Standards

- This model complies with the latest ISO, JIS, DIN, ASME, CNOMO and other standards, and has cleared the requirements for the European safety standard CE marking. It supports operation using Japanese, English, German, French, Italian, Spanish, Chinese, and Korean. Contact ACCRETECH before taking this model to a country outside of Japan.

Reanalysis After One Measurement

- Data can be reanalyzed after one measurement is performed. The measurement standard (linear, first half, latter half, round surface, both end) can be changed to set the measuring range for analysis, or the defective data for a notch can be removed.

Evaluation Functions Dramatically Strengthened

- A variety of customer requests for more evaluation functions have been reflected in the 1400D. These include accommodation of standards for film thickness measurement (step/area), wear volume calculation (superimposed profile area) and LCD glass substrate (special waviness).

Flexible input and output function

- Import and export function enables to paste picture data into measured result and to paste measured wave form data into a program on the market.

Specifications

● Two-Dimensional Roughness

Model		SURFCOM 1500DX/SD
Measuring range / Resolution	Z axis (vertical)	1000 μ m/0.02 μ m – 6.4 μ m/0.0001 μ m
	X axis (horizontal)	100mm/0.04 μ m or 32,000 points (max. data items) (300,000 data uptake points)
Straightness		(0.05 + 1.0L / 1,000) μ m L: Measuring length [mm]
Analysis items	Standards	Complies with JIS-2001, JIS-1994, JIS-1982, ISO-1997, ISO-1984, DIN-1990, ASME-1995 and CNOMO.
	Parameters	Ra, Rq, Ry, Rp, Rv, Rc, Rz, Rmax, Rt, Rz.J, R3z, Sm, S, R Δ a, R Δ q, R λ a, R λ q TILT A, Ir, Pc, Rsk, Rku, Rk, Rpk, Rvk, Mr1, Mr2, VO, K, tp, Rmr, tp2, Rmr2, R δ c AVH, Hmax, Hmin, AREA, NCRX, R, Rx, AR, NR, CPM, SR, SAR
	Evaluation curves	Section profile curve, roughness curve, filtered waviness curve, filtered center line waviness curve, rolling circle waviness curve, rolling circle center line waviness curve, DIN4776 special curve, roughness motif curve, waviness motif curve, envelope waviness curve
	Surface characteristics graphs	Load curve, amplitude distribution (ADF) curve, power graph
Magnification	Tilt correction	Linear correction, round surface correction, first half correction, latter half correction, both end correction, spline curve correction (linear, round surface and both end correction possible at arbitrary range)
	Vertical magnification (Z axis)	Set desired value or automatic: 50, 100, 200, 500, 1K, 2K, 5K, 10K, 20K, 50K, 100K, 200K, 500K
	Horizontal magnification (X axis)	Set desired value or automatic: 0.1, 1, 2, 5, 10, 20, 50, 100, 200, 500, 1K, 2K, 5K, 10K, 20K
Type of filter		Standard filter (2RC), phase compensation filter (2RC), phase compensation filter (Gaussian)
speed	Column up/down speed (Z-axis)	3 to 10 mm/s
	Measuring speed (X-axis)	(texture) 0.03 to 3 mm/s, (waviness) 0.03 to 20 mm/s
	Movement speed (X-axis)	0.03 to 60 mm/s
Detector		Tip radius: 2 μ m, Material: Diamond, Measuring force: 0.75 mN
Special functions	Measuring AI	AI function provides easy procedures, enabling beginners to make measurements.
	Waveform superimposition	Waveform curve for a maximum of 10 data items can be superimposed (ideal for wear evaluation).
	Automatic operation	Simplified auto mode and teaching mode enable fully automatic operation.

● Other Specifications

Power source/consumption	Single phase AC 100V \pm 10% 50/60Hz, 300VA
Installation dimensions	1250 (W) \times 850 (D) \times 1500 (H) mm
Weight	Approx. 125 kg

Refer to S1400D-3DF for 3D roughness specifications.

★ Dimensions and weight are for the DX-12 Type.