

NEW

## PULCOM V7,V8

In-Process • Post-Process Indicator Control Units



PULCOM V7



PULCOM V8

## Features

### Intelligent Judgment Control

The V7 and V8 have a variety of standard calculation and compensation functions. A host of optional software allows numerous functions to be added.

### In-Process/Post-Process Use

Two models are available: the V7 for in-process machining (analog meter model), and the V8 for post-process applications (LED digital model). However, both models can be used for in-process machining and post-process applications.

### Multipoint Measurement with 4-Channel Simultaneous Parallel Processing

The provision of 2 or 4 input detectors enable simultaneous parallel/calculation processing and overall judgment processing for a maximum of four items.

## Optional Functions

- BCD/binary input/output function
- RS232C input/output function
- Memory function (P-type memory, W-type memory)
- External auto-zero function
- Size shift function
- Auto calibration
- External grade function
- Tolerance changeover function
- Zero shift function
- Smoothing function
- Calculating input function
- Repeat counter function
- Dimension error detect function
- BCD judgment output function

### Expanded Display Functions

The V7 for in-process machining has a large analog meter and digital display.

The V8 for post-process applications is equipped with an LED digital meter.

### Dramatically Enhanced Operational Ease

A rotary switch facilitates intuitive operation. In addition to easy setting of various conditions and display of compensation values, a fluorescent display facilitates one-glance confirmation of measured values and results.

### Compatible with PULCOM U2000A

The units can be used to replace the U2000A in most cases.

### Superior Maintenance Ease

The provision of a large-capacity battery provides long life.

## Outer Appearance/Dimension Diagram

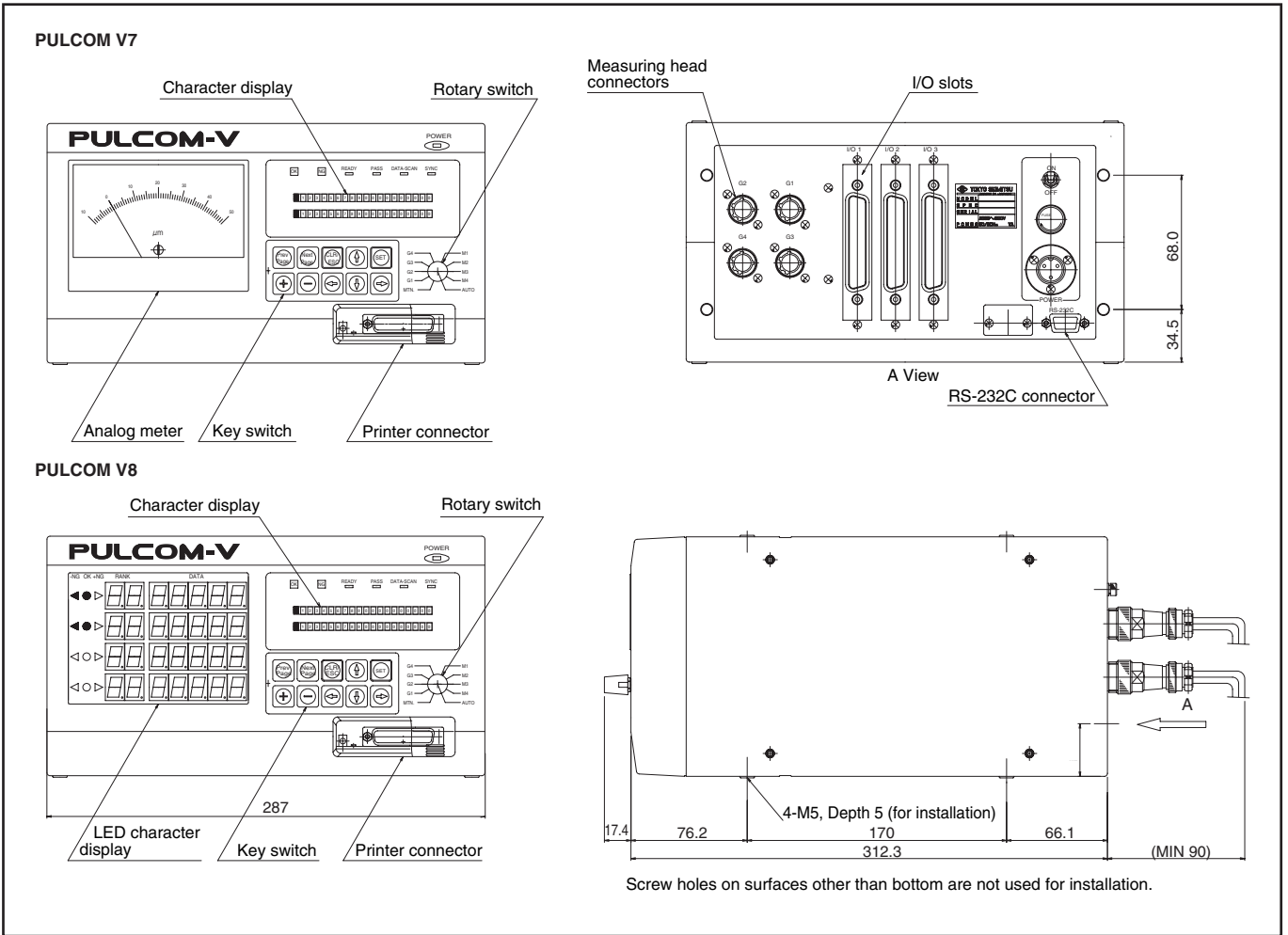

### Specifications

Model		PULCOM V7	PULCOM V8
Application		In-process/post-process	In-process/post-process
No. of detector inputs		Max. 4 (2/4 channel type)	Max. 4 (2/4 channel type)
No. of simultaneous processing inputs		Max. 4	Max. 4
Judgment inputs	Overall	○	○
	Individual	Max. 20 (Example 20 outputs: 1 simultaneous process 5 outputs (each): 4 simultaneous processes)	Max. 20 (Example 20 outputs: 1 simultaneous process 5 outputs (each): 4 simultaneous processes)
Display		Indicator Fluorescent character display (simultaneous display)	LED character display Fluorescent character display (simultaneous display)
Main functions	Auto master set	○	○
	Zero shift	Option	Option
	Grade	○ (External grade with option)	○ (External grade with option)
	Memory	Option (Max., min., peak-to-peak)	Option (Max., min., peak-to-peak)
	Data output	Option RS-232C, BCD, printer	Option RS-232C, BCD, printer
	Statistical processing	Option	Option
	Size shift	Option 40 dimensions/1 judgment, 160 dimensions/4 judgments	Option 40 dimensions/1 judgment, 160 dimensions/4 judgments
Power supply		85 – 250V AC, 50VA	85 – 250V AC, 50VA
Size and weight		287(W) × 325(D) × 159(H)mm, 7 kg	287(W) × 325(D) × 159(H)mm, 7 kg

### I/O-1 Input/Output Signals

Standard port for basic functions

- (1) Connector: 57E-30500-D76 (50P, made by DDK)
- (2) Cable: Provided with 6m shielded wire cable, outer diameter  $\phi$  12.4
- (3) Output specifications: Select open collector or open drain
- (4) Pin arrangement

Output			
Signal name	No.	ID	
Meas. 1	-NG	1 Pink 1	
	OK3	2 Pink 2	
	OK2	3 Pink 3	
	OK1	4 Pink 4	
	+NG	5 Pink 5	
	Meas. 2	-NG	6 Pink 6
		OK3	7 Pink 7
		OK2	8 Pink 8
		OK1	9 Pink 9
		+NG	10 Pink 10
Meas. 3	-NG	11 Yellow 1	
	OK3	12 Yellow 2	
	OK2	13 Yellow 3	
	OK1	14 Yellow 4	
	+NG	15 Yellow 5	
	Meas. 4	-NG	16 Yellow 6
		OK3	17 Yellow 7
		OK2	18 Yellow 8
		OK1	19 Yellow 9
		+NG	20 Yellow 10
Overall OK output	21	Green 1	
Overall NG output	22	Green 2	
Auto master complete output	23	Green 3	
Auto master NG	24	Green 4	
Meas. prep. complete output (READY)	25	Green 5	
Retract OK	26	Green 6	
All judgment complete output	27	Green 7	
Judgment complete output	28	Green 8	
CPU RUN	29	Green 9	
	30	Green 10	
All auto master complete output	31	Gray 1	
N.C.	32	Gray 2	
Output signal common terminal (COMMON)	33	Gray 3	

\* The above is an ordinary example. The relationship between the signals and pin numbers may change depending upon the specifications.

### I/O-2 Input/Output Signals (Optional)

Expansion port for BCD/binary data output

- (1) Connector: 57E-30360-D76 (36P, made by DDK)
- (2) Cable: Provided with 6m shielded wire cable, outer diameter  $\phi$  10.8
- (3) Output specifications: Select open collector, open emitter or open drain
- (4) Pin arrangement

Output		
Signal name	No.	ID
BCD output $1 \times 10^n$	1	Pink 1
BCD output $2 \times 10^n$	2	Pink 2
BCD output $4 \times 10^n$	3	Pink 3
BCD output $8 \times 10^n$	4	Pink 4
BCD output $1 \times 10^{n+1}$	5	Pink 5
BCD output $2 \times 10^{n+1}$	6	Pink 6
BCD output $4 \times 10^{n+1}$	7	Pink 7
BCD output $8 \times 10^{n+1}$	8	Pink 8
BCD output $1 \times 10^{n+2}$	9	Pink 9
BCD output $2 \times 10^{n+2}$	10	Pink 10
BCD output $4 \times 10^{n+2}$	11	Yellow 1
BCD output $8 \times 10^{n+2}$	12	Yellow 2
BCD output $8 \times 10^{n+3}$	13	Yellow 3
Over	14	Yellow 4
"-" polarity	15	Yellow 5
Data valid	16	Yellow 6
Output signal common terminal (COMMON)	17	Yellow 7

Output range $\mu$	Resolution $\mu$	Over signal $\mu$
9.99	0.01	10.00 or more
19.99	0.01	20.00 or more
99.9	0.1	100.00 or more
199.9	0.1	200.00 or more
999	1	1000 or more
1999	1	2000 or more

\* The above is an example for BCD output specifications. The relationship between the signals and pin numbers may change depending upon the specifications.

### I/O-3 Input/Output Signals (Optional)

Expansion port for optional function control signals

- (1) Connector: 57E-30360-D76 (36P, made by DDK)
- (2) Cable: Provided with 6m shielded wire cable, outer diameter  $\phi$  10.8
- (3) Output specifications: Select open collector or open drain
- (4) Pin arrangement

Output		
Signal name	No.	ID
Workpiece select input (BCD $4 \times 10^1$ )	1	Pink 1
Workpiece select input No. 1 or (BCD $1 \times 10^0$ )	2	Pink 2
Workpiece select input No. 3 or (BCD $4 \times 10^0$ )	3	Pink 3
Workpiece select input No. 4 or (BCD $8 \times 10^0$ )	4	Pink 4
Workpiece select input No. 5 or (BCD $1 \times 10^1$ )	5	Pink 5
Workpiece select input No. 6 or (BCD $2 \times 10^1$ )	6	Pink 6
	7	Pink 7
	8	Pink 8
Memory circuit 3 reset	9	Pink 9
Memory circuit 4 reset	10	Pink 10
	11	Yellow 1
	12	Yellow 2
	13	Yellow 3
	14	Yellow 4
Memory circuit 1 external synchronize	15	Yellow 5
Memory circuit 2 external synchronize	16	Yellow 6
Memory circuit 3 external synchronize	17	Yellow 7
Memory circuit 4 external synchronize	18	Yellow 8
	19	Yellow 9
Workpiece select input No. 2 or (BCD $2 \times 10^0$ )	20	Yellow 10
N.C.	21	Green 1
N.C.	22	Green 2
N.C.	23	Green 3
N.C.	24	Green 4
Input common terminal (COMMON)	25	Green 5

\* The above is an example when the optional workpiece change and memory function are provided. The relationship between the signals and pin numbers may change depending upon the specifications.

Input		
Signal name	No.	ID
Meas. No. 1 judgment start command	34	Gray 4
Meas. No. 2 judgment start command	35	Gray 5
Meas. No. 3 judgment start command	36	Gray 6
Meas. No. 4 judgment start command	37	Gray 7
Meas. No. 1 judgment reset	38	Gray 8
Meas. No. 2 judgment reset	39	Gray 9
Circuit No. 1 memory reset	40	Gray 10
Meas. No. 1 auto master command	41	White 1
Meas. No. 2 auto master command	42	White 2
Meas. No. 3 auto master command	43	White 3
Meas. No. 4 auto master command	44	White 4
Circuit No. 2 memory reset	45	White 5
Analog meter select $2^0$	46	White 6
Analog meter select $2^1$	47	White 7
Meas. No. 3 judgment reset	48	White 8
Meas. No. 4 judgment reset	49	White 9
Input common terminal (COMMON)	50	White 10

- Make sure to ground the shielded wiring.
  - Do not connect any terminals to the empty items.
  - Input signal: 10mA or less per signal.
  - Output signal: Use at DC24V, 40mA or less.
- (\*1) Example of a sizing instrument with post.  
(\*2) Example of 4 items of post

Input		
Signal name	No.	ID
Measurement 4 workpiece pass	26	Green 6
Measurement 3 workpiece pass	27	Green 7
Measurement 2 workpiece pass	28	Green 8
Measurement 1 workpiece pass	29	Green 9
	30	Green 10
	31	Gray 1
	32	Gray 2
	33	Gray 3
N.C.	34	Gray 4
N.C.	35	Gray 5
Output signal common terminal (COMMON)	36	Gray 6

- Make sure to ground the shielded wiring.
- Do not connect any terminals to the empty items.
- Input signal: 10mA or less per signal.
- Output signal: Use at DC24V, 40mA or less.

### I/O Cable Identification

(Common for I/O-1, I/O-2 and I/O-3)

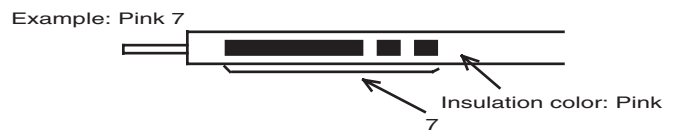

- Make sure to ground the shielded wiring.
- Do not connect any terminals to the empty items.
- Input signal: 10mA or less per signal.
- Output signal: Use at DC24V, 40mA or less.

### ■ Power Source

- (1) Voltage: AC85 - 250V, Power consumption: 50VA Max.  
 (2) Connector: HS16P-3 (made by Hirose Electric)  
 (3) Cable: Provided with 6m 3-wire cable, Outer diameter  $\phi$ 8.4mm

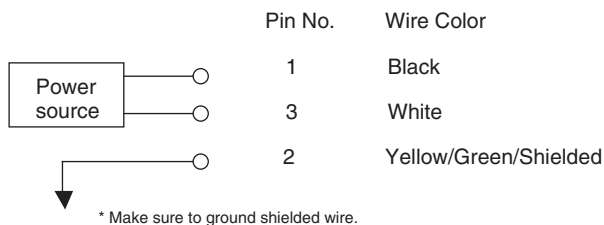

### ■ RS-232C Communication Functions (options)

- (1) Connector: D-sub 9-pin connector (male), inch threads  
 (2) Communication specifications

Communication standard	Complies with EIA, RS-232C, JIS-C6361
Communication method	All duplex
Synchronization	Asynchronous
DTE/DCE classification	DTE
Transmission code	ASCII
Data bit length	7 or 8 bits
Stop bit length	1 or 2 bits
Parity check	Even, odd, none
Baud rate (bps)	1200, 2400, 4800, 9600, 19200

- (3) Allocation of pin numbers and signals

Pin No.	Signal name	Signal direction	Outline
1	(NC)	-	Not used
2	RD	Input	Receive data
3	TD	Output	Transmit data
4	DTR	Output	Data terminal ready (Turned On when power goes On)
5	GND	-	Signal ground
6	DSR	Input	Data set ready (Operation can be performed when On)
7	RTS	Output	Request to send (Turned On when power goes On)
8	CTS	Input	Can transmit (Operation can be performed when On)
9	(NC)	-	Not used

### ■ RS-232C Cable (optional)

- (1) Cable: AWG#28 twisted pair braided shield, UL2464  
 (2) Connector: Control unit side: 9-wire male (#4-40 inch)  
 External device side: 25-wire male (M2.6 mm)

- (3) Connection diagram

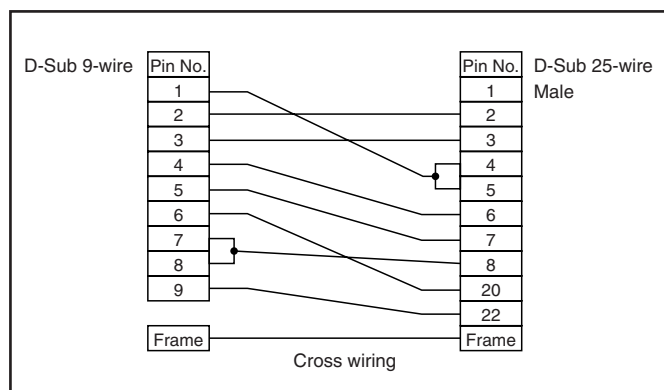

\* The RS-232C cable is not included in the RS-232C communication option.  
 If required, please separately order.